



Water Temperature Control - Groups of Fixtures

Thermostatic

Rada 50

Rada 50 Thermostatic Mixing Valve for institutional group fixture water temperature control when ASSE 1016 certified individual fixture controls are installed at each point of use

Rada 50 is also applicable for accurate water temperature control in single open outlet or "dead leg" multiple-point-of-use industrial process applications. Capable of close outlet water temperature control at flow rates between 2 and 98 gpm (7.5 and 371 lpm).

Rada 50 may be installed in parallel to increase outlet flow rates. Refer to page 19.

Rada 50 Offers:

- Dual thermostatic elements provide redundancy in the event of individual thermostat failure
- Typical outlet temperature control +/-2°F
- Adjustable single temperature lockout (removable key)
- Thermal shutdown mode upon inlet supply failure

* Shutdown mode is defined as a thermally driven bias toward the hot seat within the valve. This action may or may not reduce the outlet flow rate relative to inlet supply and outlet set point temperatures. Large capacity Thermostatic Mixing Valves (1-1/2" and 2"/40 and 50 mm) cannot be guaranteed to fully shut off in the event of a cold water supply failure.

IMPORTANT NOTE: If Rada 50 is to be used for group fixture or zoned temperature control in institutional showering, bathing or hand washing, then ASSE 1016 certified individual fixture controls must be installed at each point of use.

If the design/specification does not call for ASSE 1016 certified individual fixture fittings, then the largest group or zoned mixer suggested is Rada 425. If higher flows are required, create more groups/zones.

Technical Specifications

- 2" NPT (50 mm) inlets and 2" (50 mm) NPT outlet
- DZR brass/stainless steel construction
- Operating pressures
 - Maximum: 150 psi (10 bar)
 - Minimum: 10 psi (.7 bar)
- Maximum pressure drop 20 psi (1.3 bar)
- Integral combination inlet check valves
- Integral thermometer
- ASSE 1017 and CSA B125 certified
- Shipping weight 30 lbs (13.5 kg)

For fully detailed certified drawing, refer to CDLW #1042.

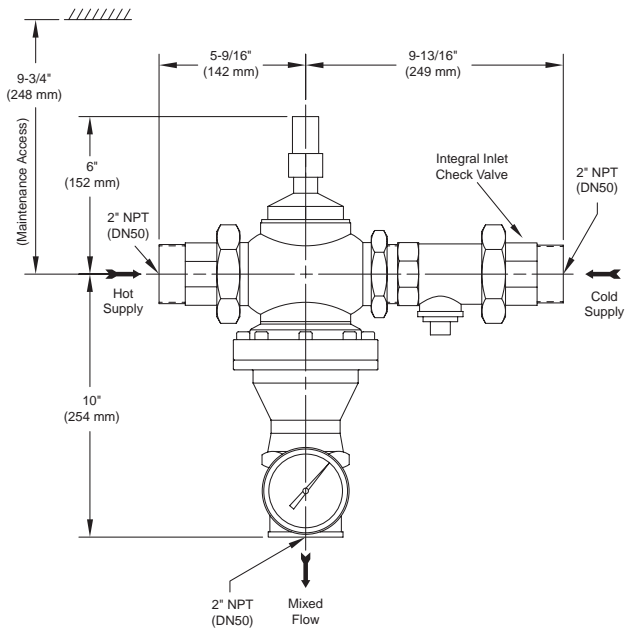
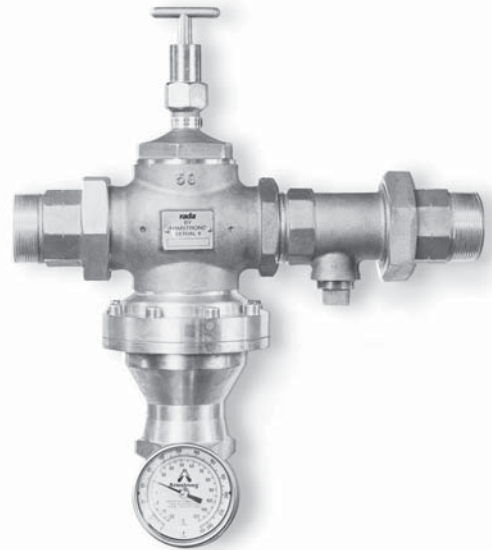

Rada Thermostatic Mixing Valves (gpm)												
Model	Pressure Drop (psi)										Min. Flow	C _v
	5	10	15	20	25	30	35	40	45	50		
320	8	11	13	15	17	19	20	22	23	24	1	3.4
425	15	22	27	31	35	38	41	44	46	49	2	6.9
40	36	51	62	72	—	—	—	—	—	—	2	16.0
50	49	70	85	98	—	—	—	—	—	—	2	22.0

All dimensions and weights are approximate. Use certified print for exact dimensions. Design and materials are subject to change without notice.

Water Temperature Control - Groups of Fixtures



Thermostatic

Rada 50-FMC

Rada 50-FMC is supplied as standard* fully assembled and pressure tested in an 26" x 30" x 10" stainless steel recessed cabinet with a 2" flange. Cabinet has a polished stainless steel piano-hinged door with a keyed cylinder lock.

Rada 50-FMC is supplied as standard under this model number for top inlet hot and cold water supplies and a bottom outlet with a left hand hinged door as indicated in adjacent drawing. Rada 50-FMC can be specified/ordered with the following piping configurations under the following model numbers:

Bottom inlets/top outlet 50-FMC-BT

* Note cabinet options under technical specifications.

Technical Specifications

- 2" (50 mm) NPT inlets and 2" (50 mm) NPT outlet
- Cabinet construction: 18 gauge #4 finish stainless steel
- Cabinet options:
 - Premium: Stainless steel 14 gauge #4 finish
 - Baked Enamel: White enameled steel 18 gauge
- Cabinet outer flange 2"
- Integral thermometer
- Integral inlet check valves
- Refer to Rada 50, page 28, for mixing valve operational and technical specifications
- Shipping weight 58 lbs (22 kg)

NOTE: Available as above in a Surface Mounted Cabinet of the same size and specification, less recess flange, under model number 50-SMC.

For a fully detailed certified drawing, refer to CDLW #1152.

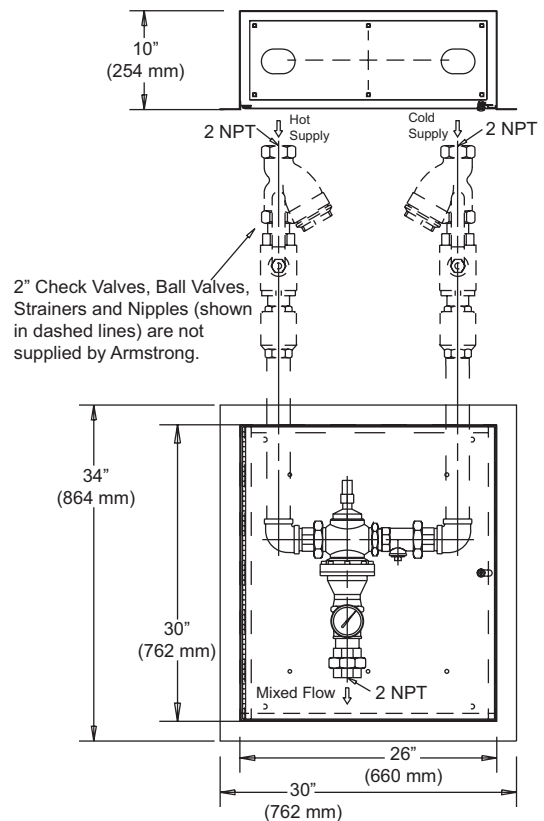
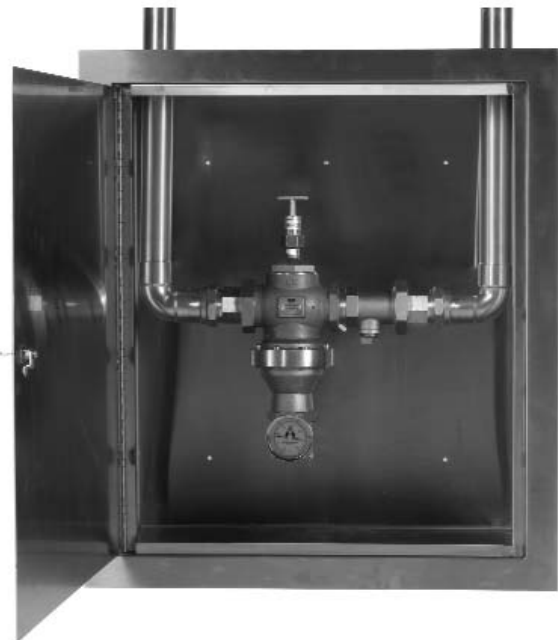

White enameled steel 18 gauge available upon request.

All dimensions and weights are approximate. Use certified print for exact dimensions. Design and materials are subject to change without notice.